



Xentry STS Trackless Speedgate

SECURITY WITHOUT HINDRANCE

Effective security of company premises requires permanent closure. Effective access for vehicles and freight traffic demands, on the other hand, access without hindrance. A Xentry STS is unique in providing security without hindrance, specifically for access to industrial sites.

Opens and closes rapidly (after each vehicle) - A Speedgate moves quickly enough to be opened and closed for each vehicle without hindrance. It prevents the need for additional barriers, waiting times and "riding and walking along".

Up to 12 meters wide - A wide entrance allows large vehicles to manoeuvre without hindrance. A Xentry STS has a width of up to 12 meters, making it unique in the market.

No guide rail - A trackless Speedgate has no top or bottom guide rail. That means no restrictions regarding vehicle clearance and a continuous road surface. Ideal for heavy and high vehicles or heavily used or dirty road surfaces.



~6 sec/5m wide Speedgate.
~13 sec/12m Speedgate (10x faster than other gate types)



safe, opening and closing at each passage prevents pedestrians from riding or walking along with the vehicle



reliable, due to top-quality components and predictive maintenance (Xense)



high usage frequency, up to 400 movements per day



safe, approved by SKG according to EN13241-1. safety features adaptable to each situation



in total cost of ownership (purchase + use) the most effective choice on the market



HTC has delivered over 3500 Speedgates to satisfied customers worldwide.



PCB

TÜV certified controller in column or external control box. Controller with frequency converter 0.75 kW. power: CEE-type plug, 16 A, 230Vac.

Panels

Solid panels with several panel styles. HTC Safety hinges with integrated cable routing. Maintenance-free bearings. Guiding mechanism for crush prevention.

Drive system

2 Motors in column : 0.18 kW, IP54. drive system mechanically locked in closed position.

Security

Class 3 photo cells and safety contact edges. Optional, vehicle detection loops and light curtain

Preservation

Hot dip galvanized according to NEN-EN-ISO 1461. Option: two-layer polyester powder coating, 120 µm total, in RAL colour.

Other options

Matching pedestrian gates & fencing, acoustic & optical Warning Systems, Traffic control with multiple LED lights & strips, Access Control Systems, road marking etc.

Columns

- Heavy steel tubes
- 220 x 220 mm (up to 8m)
- 300 x 300 mm (8 - 12m)

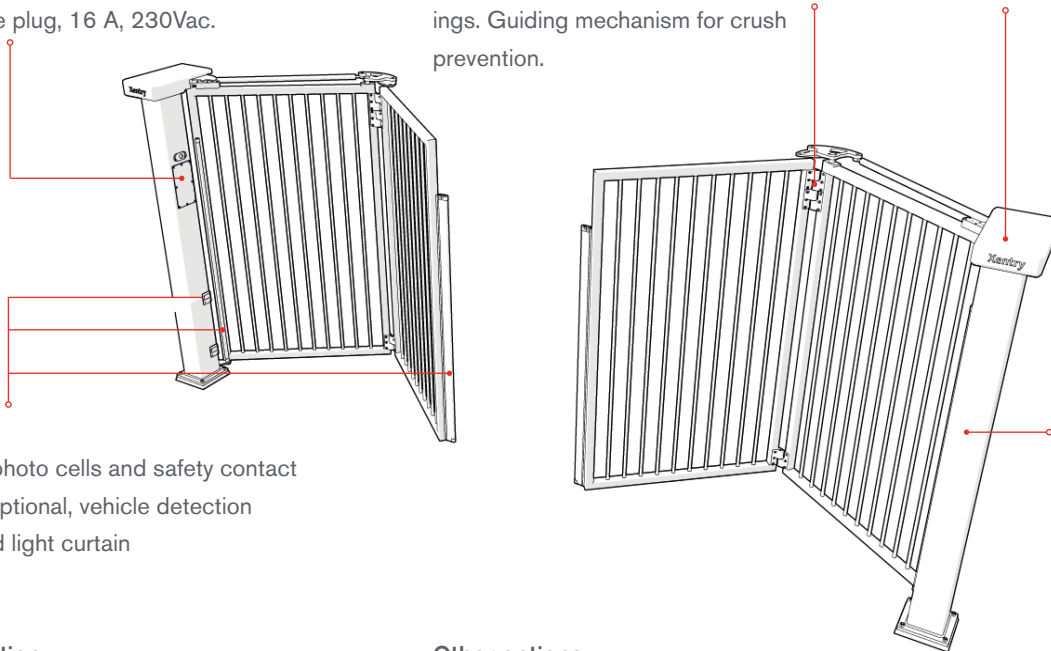

Xense core module integrated as standard. Xense connect module installed by Xense service.

THE SPEEDGATE XENTRY STS IS USED IN TANK STORAGE / CHEMICAL AND LOGISTICS INDUSTRIES/ PORTS

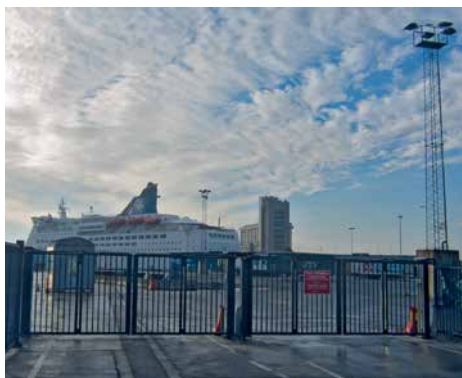

FOR MORE INFORMATION GO TO WWW.HTC-PS.COM

20170418 | HTC is continuously innovating, therefore information in this brochure is not legally binding.



HTC parking & security bv

Tweede Bloksweg 72 | 2742 KL | Waddinxveen | The Netherlands
T +31 88 027 70 88 | info@htc-ps.com | www.htc-ps.com